

PLAN

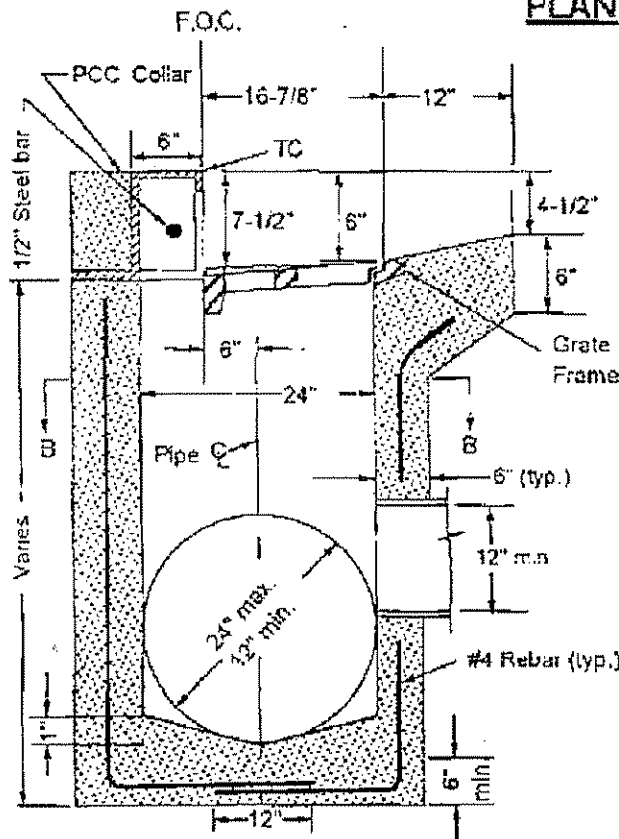

SECTION A-A

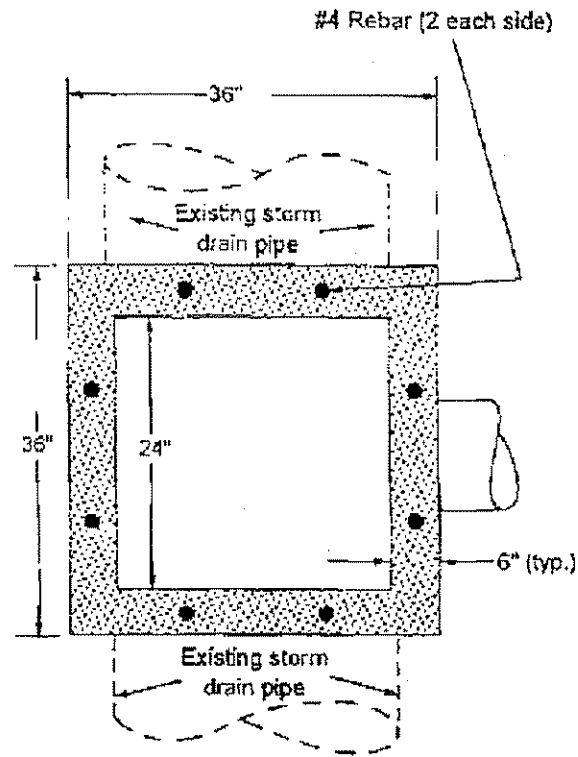

SECTION B-B

NOTES:

1. Curb casting, gutter frame and grate shall be South Bay Foundry SBF1901 or Phoenix Iron Works No.P-6001 or approved equal.
2. PCC Collar shall not be constructed where sidewalk is contiguous to back of curb.
3. All PCC shall be 'Class A' (6 sack/c.y.), or approved 3000 PSI mix.
4. Subject to City Engineer approval on case by case.

CITY OF MILPITAS, ENGINEERING DIVISION

STANDARD DRAWING

NO. 460

CURB STORM DRAIN INLET RETROFIT

DATE : 6/15/10

REVISION

DATE

1

1997

2

2001

3

2010

3

APPROVED BY:

PUBLIC WORKS DIRECTOR / CITY ENGINEER RCE No.40283

SHEET 1 OF 1